

AGM TECHNOLOGY  
ABT PowerLine SGP Series

## SGP12-90

12V90Ah(20hr)

ABT PowerLine SGP Series is a general purpose battery according to Eurobat Classification with 10 years design life for standby application. As with all ABT batteries, all are rechargeable, highly efficient, leakage proof and maintenance free.

### Complying standards:

IEC 61056-1/2-2002  
JIS C8702-1/2-2009



### Specification

Cells Per Unit	6
Voltage Per Unit	12V
Nominal Capacity 20°C (68°F)	90Ah @20hr-rate to 1.75V Per cell 83.25Ah @10hr-rate to 1.75V Per cell 56.25Ah @1hr-rate to 1.60V Per cell
Weight	Approx 29kg(63.95lbs)
Maximum Discharge Current	855A (5 sec)
Short circuit current	3015A
Maximum charge current	27A(30% of rated capacity)
Internal Resistance	Approx 3.98 mOhms
Mass Energy(Wh/kg)	37. 2
Volumic energy(Wh/L)	101. 3
Operating Temperature Range	Discharge -20~60°C; Charge -10~60°C; Storage -20~60°C
Nominal Operating Temperature Range	20°C±3 °C (68°F±5 °F)
Float Charging Voltage	13.5 t o 13.8 VDC/unit Average at 20°C(68°F)
Equalization and Cycle Service	14.4 to 15.0 VDC/unit Average at 20°C(68°F)
Self Discharge	ABT batteries can be stored for more than 6 months at 20°C(68°F). Please charge batteries before using. For higher temperatures the time interval will be shorter.
Terminal	Insert thread and bolt M6× 16
Torque strength in Nm	12~16
Container Material	ABS(UL94-HB) Flammability resistance of UL94-V0 can be available upon request.
Handle Type	Plastic
Flame arrester	Yes

### Dimensions / Terminal

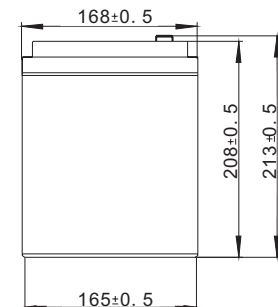
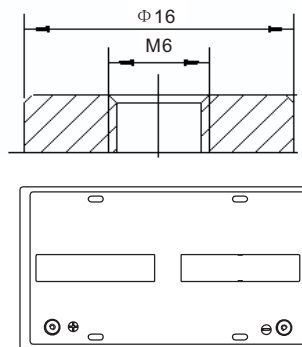
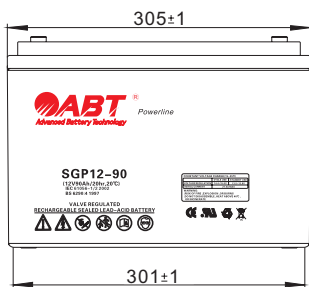

### Constant Current Discharge Data ( Amperes at 20°C )

End Volt. Per Cell	5min	10min	15min	30min	1h	2h	3h	4h	5h	8h	10h	20h	24h
1.60	270.7	208.8	155.1	95.59	56.25	35.42	24.90	19.20	16.13	11.02	8.780	4.749	3.940
1.65	248.0	197.5	148.8	92.57	55.60	34.51	24.40	18.85	15.83	10.80	8.637	4.674	3.910
1.70	233.6	185.3	143.3	89.80	54.50	33.51	23.90	18.46	15.52	10.54	8.480	4.590	3.870
1.75	215.4	175.5	138.2	87.20	53.30	32.50	23.39	17.99	15.20	10.26	8.325	4.500	3.836
1.80	197.3	165.7	131.8	84.70	51.90	31.24	22.84	17.58	14.84	9.969	8.114	4.427	3.790

### Constant Power Discharge Data ( Watts per cell at 20°C )

End Volt. Per Cell	5min	10min	15min	30min	1h	2h	3h	4h	5h	8h	10h	20h	24h
1.60	445.5	347.6	264.0	165.4	99.23	60.92	43.76	33.83	28.27	19.67	15.58	8.476	7.168
1.65	419.4	337.8	258.7	162.9	98.11	60.00	43.36	33.49	27.98	19.40	15.43	8.381	7.130
1.70	404.5	327.2	254.0	160.2	96.99	59.23	42.80	33.08	27.73	19.02	15.28	8.305	7.092
1.75	387.3	315.7	248.2	157.6	95.70	58.19	42.40	32.65	27.49	18.68	15.13	8.229	7.063
1.80	359.5	303.5	241.0	154.6	94.26	56.99	41.76	32.27	27.20	18.28	14.99	8.154	7.035

**Trickle (or float) Service Life**

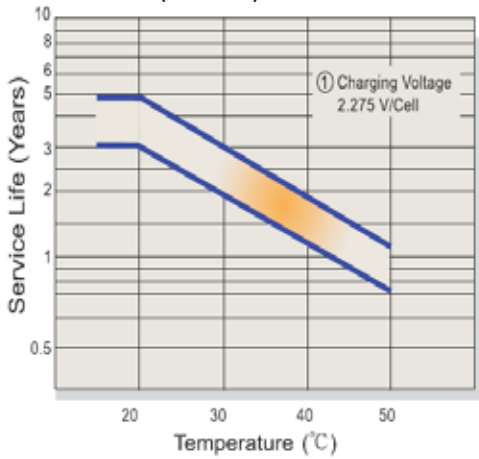

**Capacity Retention Characteristic**

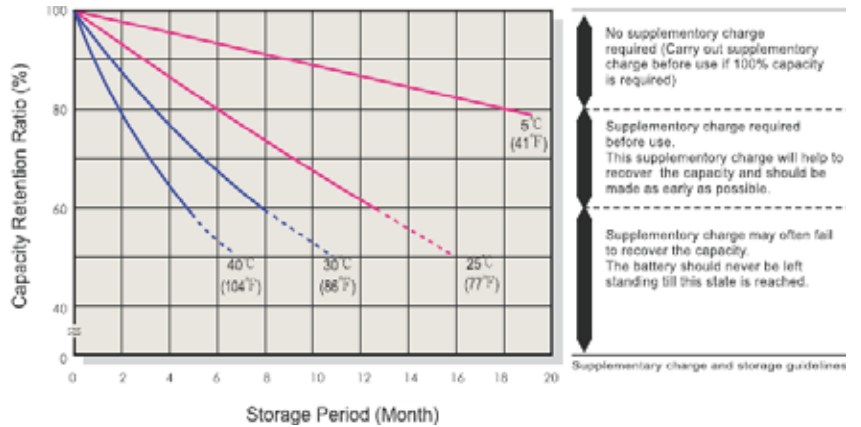

**Battery Voltage and Charge Time for Standby Use**

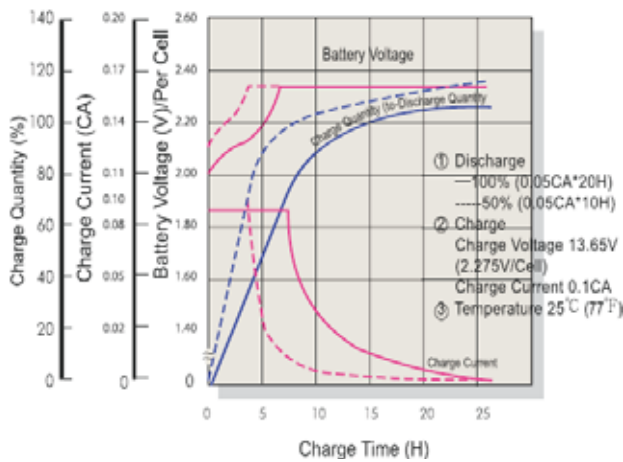

**Terminal Voltage (V) and Discharge Time(20°C/68°F)**

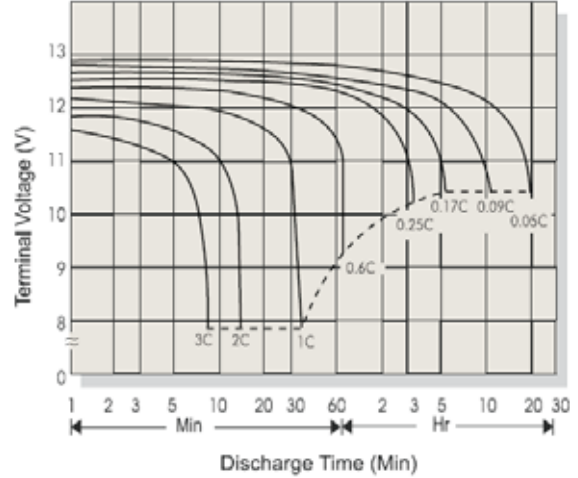

**Charge Voltage depend on the temperature**

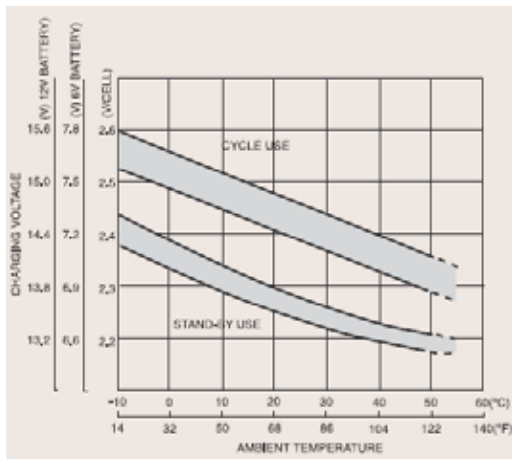

**Capacity depend on the temperature**

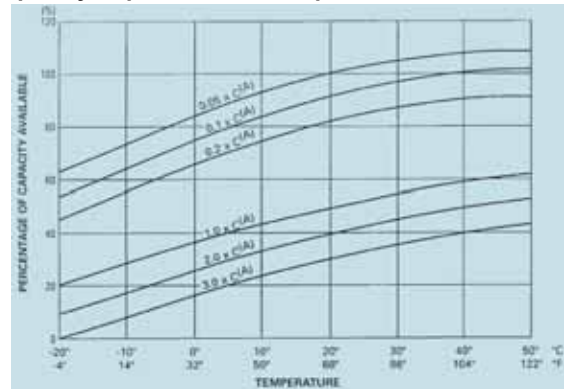

**Charging Procedures**

Application	Charge Voltage(V/Cell)			Max. Charge Current
	Temperature	Set Point	Allowable Ranges	
Cycle Use	20°C(68°F)	2.45	2.40~2.50	0.3C
Standby	20°C(68°F)	2.275	2.25~2.30	0.3C

**Discharge Current VS. Discharge Voltage**

Final Discharge Voltage V/Cell	1.75	1.70	1.60	1.40
Discharge Current(A)	0.2C>(A)	0.2C<(A)<0.5C	0.5C<(A)<1.0C	(A)>1.0C

**Contact information**

Shandong Sacred Sun Power Sources Co., Ltd.  
Add: No.1, Shengyang Road, Qufu City, Shandong Province, China 273100  
Tel: +86-537-4438 666 extn 6027 Fax: +86-537-4411 936  
Website: <http://www.abtbatt.com> E-mail: [sales@abtbatt.com](mailto:sales@abtbatt.com)

ABT VRLA Battery: Available Power Range From 7Ah to 3000Ah

Copyright SACREDSUN,  
All rights reserved.  
(Edition: May,2011)