

目 录

contents

说明：本标准 EFHP 系列电池依据壳体外形尺寸分类排列。每页所列配件仅适用于如标准提供连线图所示的电池布局方式（每组四只），其它布局方式需重新设计；

Note：In this standard, EFHP batteries are arranged by the container outside dimensions. The accessories of each page just apply to the battery layout which the drawing show in this standard (4cells per suite), and for others they need to redesign.

序号 SN	电池类型 battery types	页码 page
1	目录 contents	1
2	EFTA12-100	2
3	EFTA12-125	3
4	EFTA12-150/ EFTA12-160/ EFTA12-175	4
5	EFTB12-50（前部连接 FC）	5
6	EFTB12-50（顶部连接 TC）	6
7	EFTB12-80/EFTB12-85	7
8	EFTB12-100（前部连接 FC）	8
9	EFTB12-100（顶部连接 TC）	9
10	EFTB12-125/EFTB12-150/ EFTB12-155（前部连接 FC）	10
11	EFTB12-125/ EFTB12-150/ EFTB12-155（顶部连接 TC）	11
12	附页 Annex	12-15

壳体技术特性

technical characteristics of container

长 L	宽 W	高 H	总高 max height	端子数 the number of pillars
558	125	230	230	2

EFTA12-100

连接配件

connecting accessories

照片 picture	名称 name	特性 characteristic	规格型号 reference	数量 QTY
	联接铜排 rigid connector between cells	100x25x3mm QDU.860(03).D02ZP(A)	FTP75/3	3
	接线端子 end lug	自制 QDU.890(01).D01DZ(A)	SC70-8A	3
	绝缘扳手 insulated spanner	QDU.950(02).A14WX	TB8	1
	数字序号 numbers	1 ~ 4		1
	排气管 Exhaust pipe	QDU.891.D01PG(A)		4
	排气管塞 air pipe closure	QDU.781.D01PS(A)		1
	导气管 air pipe	QDU.891.D00DG(A)	A: 5000mm	1
			B: 122mm	3
	电池护罩 battery shield	QDU.631.D01HZ(A)	出厂前 安装在 电池上	4
	接线组件 connection subassembly	QDU.516.D01JZ(A)		8
	螺栓 screw	不锈钢 stainless steel		GB818-85-M8 x 16
	平垫 flat washer	QDU.931(01).D01DQ(A)		8

连线图

drawing

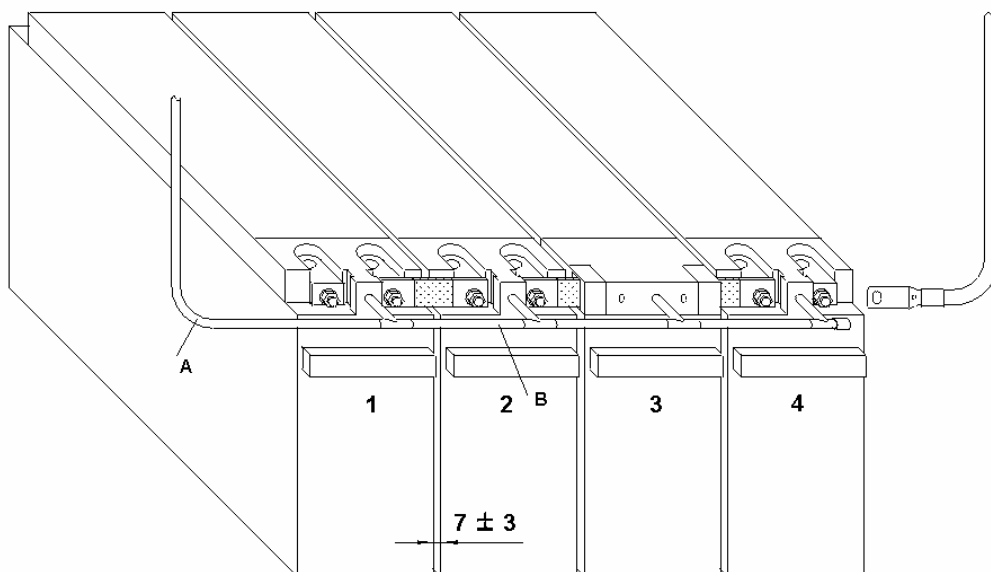

壳体技术特性

technical characteristics of container

长 L	宽 W	高 H	总高 max height	端子数 the number of pillars
558	125	270	270	2

EFTA12-125

连接配件

connecting accessories

照片 picture	名称 name	特性 characteristic	规格型号 reference	数量 QTY	
	联接铜排 rigid connector between cells	100x25x4mm QDU.860(05).D01ZP(A)	FTP75/4A	3	
	接线端子 end lug	自制 QDU.890(01).D01DZ(A)	SC70-8A	3	
	绝缘扳手 insulated spanner	QDU.950(02).A14WX	TB8	1	
	数字序号 numbers	1~4		1	
	排气管 Exhaust pipe	QDU.891.D01PG(A)		4	
	排气管塞 air pipe closure	QDU.781.D01PS(A)		1	
	导气管 air pipe	QDU.891.D00DG(A)	A:5000mm	1	
			B:122mm	3	
	电池护罩 battery shield	QDU.631.D01HZ(A)	出厂前 安装在 电池上	4	
	接线组件 connection subassembly	QDU.516.D01JZ(A)		8	
	螺栓 screw	不锈钢 stainless steel		GB818-85-M8 x 16	8
	平垫 flat washer	QDU.931(01).D01DQ(A)			8

连线图

drawing

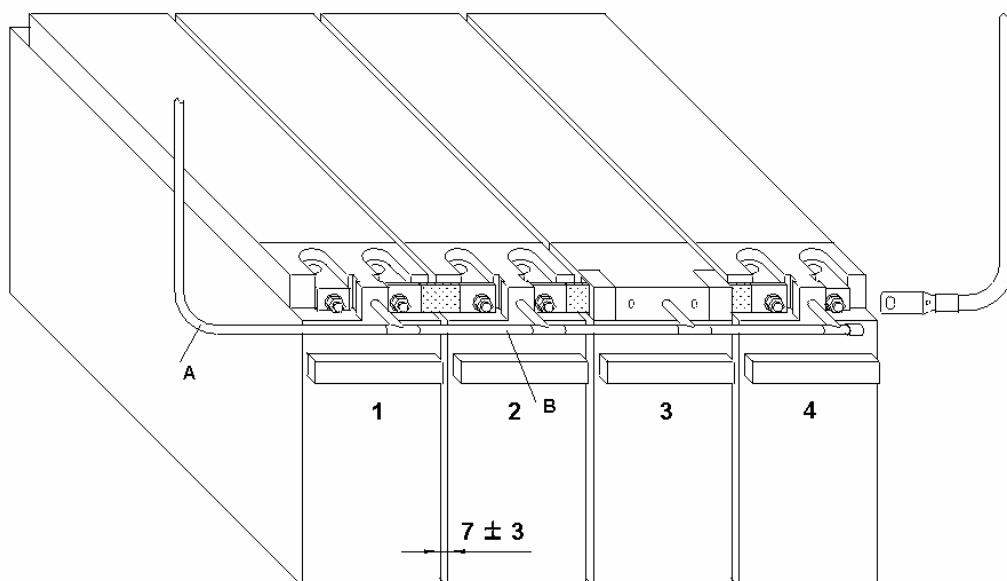

壳体技术特性

technical characteristics of container

EFTA12-150
EFTA12-160/ EFTA12-175

连接配件

connecting accessories

长 L	宽 W	高 H	总高 max height	端子数 the number of pillars
558	125	311	311	2

照片 picture	名称 name	特性 characteristic	规格型号 reference	数量 QTY
	联接铜排 rigid connector between cells	100x25x4mm QDU.860(05).D01ZP(A)	FTP75/4A	3
	接线端子 end lug	自制 QDU.890(01).D01DZ(A)	SC70-8A	3
	绝缘扳手 insulated spanner	QDU.950(02).A14WX	TB8	1
	数字序号 numbers	1~4		1
	排气管 Exhaust pipe	QDU.891.D01PG(A)		4
	排气管塞 air pipe closure	QDU.781.D01PS(A)		1
	导气管 air pipe	QDU.891.D00DG(A)	A:5000mm	1
			B:122mm	3
	电池护罩 battery shield	QDU.631.D01HZ(A)	出厂前 安装在 电池上	4
	接线组件 connection subassembly	QDU.516.D01JZ(A)		8
	螺栓 screw	不锈钢 stainless steel		GB818-85-M8 x 16
	平垫 flat washer	QDU.931(01).D01DQ(A)	8	

连线图

drawing

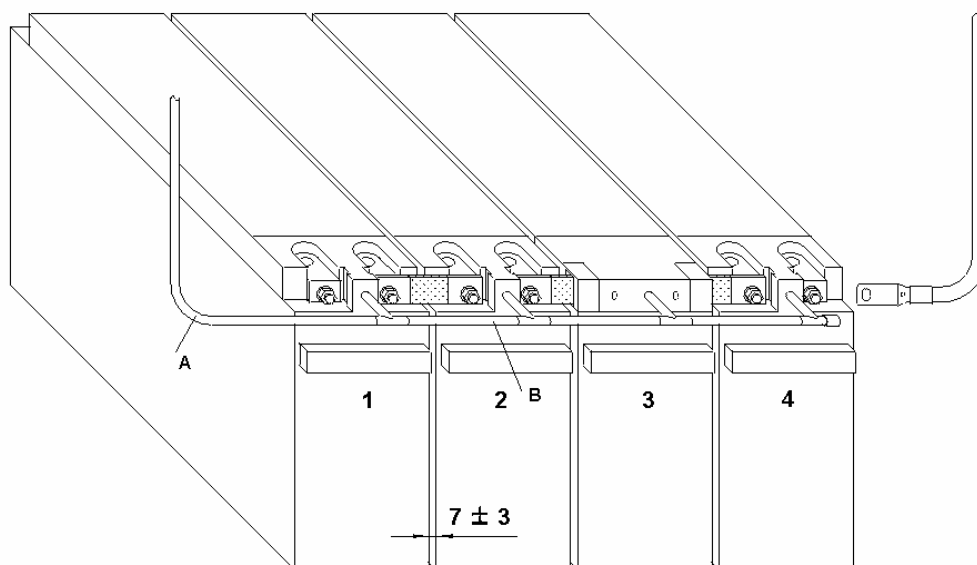

壳体技术特性

technical characteristics of container

EFTB12-50(前部连接 FC)

连接配件

connecting accessories

此连接方式适用于通信系统

This connection methods is suitable for Telecommunication system.

连线图

长 L	宽 W	高 H	总高 max height	端子数 the number of pillars
277	105	260	260	2

照片 picture	名称 name	特性 characteristic	规格型号 reference	数量 QTY
	联接铜排 rigid connector between cells	85x20x2mm QDU.860(14).D12ZP(E)	FTP60/2	3
	接线端子 end lug	自制 QDU.890(02).D06DZ(B)	SC50-6A	3
	绝缘扳手 insulated spanner	QDU.950(05).D10WX	DB6	1
	数字序号 numbers	1 ~ 4		1
	排气管 Exhaust pipe	QDU.891.D01PG(A)		4
	导气管 air pipe	QDU.891.D00DG(A)	A: 5000mm	1
			B: 103mm	3
	排气管塞 air pipe closure	QDU.781.D01PS(A)		1
	电池护罩 battery shield	QDU.631.D09HZ(B)(AB T)	出厂前 安装在 电池上	4
	接线组件 connection subassembly	QDU.516.D09JZ(B)(AB T)		8
	螺栓 screw	不锈钢 stainless steel		GB/T5781-2000-C-M6 × 12
	平垫 flat washer	不锈钢 stainless steel	GB95-2002-C- 6	8

drawing

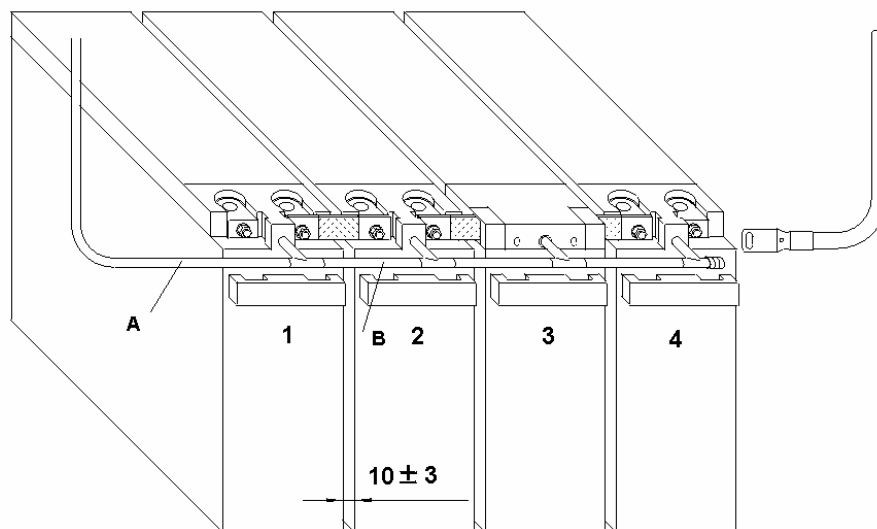

壳体技术特性

technical characteristics of container

EFTB12-50 (顶部连接 TC)









连接配件

connecting accessories

此连接方式适用于 UPS 系统

This connection methods is suitable for UPS system

长 L	宽 W	高 H	总高 max height	端子数 the number of pillars
277	105	260	260	2

照片 picture	名称 name	特性 characteristic	规格型号 reference	数量 QTY
	联接铜排 rigid connector between cells	85×20×2mm QDU.860(17).D12ZP(T)	FTP60/2A	3
	螺栓 screw	不锈钢 stainless steel	GB/T5781-2000-C-M6×12	9
	平垫 flat Washer		GB95-2002-C- 6	9
	螺母 nut		GB/T41-2000-C-M6	2
	接线端子 end lug	35 mm ²	SC35-6	3
	绝缘扳手 Insulated spanner	QDU.950(01).B00WX	TB6	1
	数字序号 numbers	1~4		1
	排气管 Exhaust pipe	QDU.891.D01PG(A)		4
	导气管 air pipe	QDU.891.D00DG(A)	A: 5000mm	1
			B: 103mm	3
	排气管塞 air pipe closure	QDU.781.D01PS(A)		1
	电池护罩 battery shield	QDU.631.D09HZ(B)(ABT)	出厂前安装在电池上	4

连线图

drawing

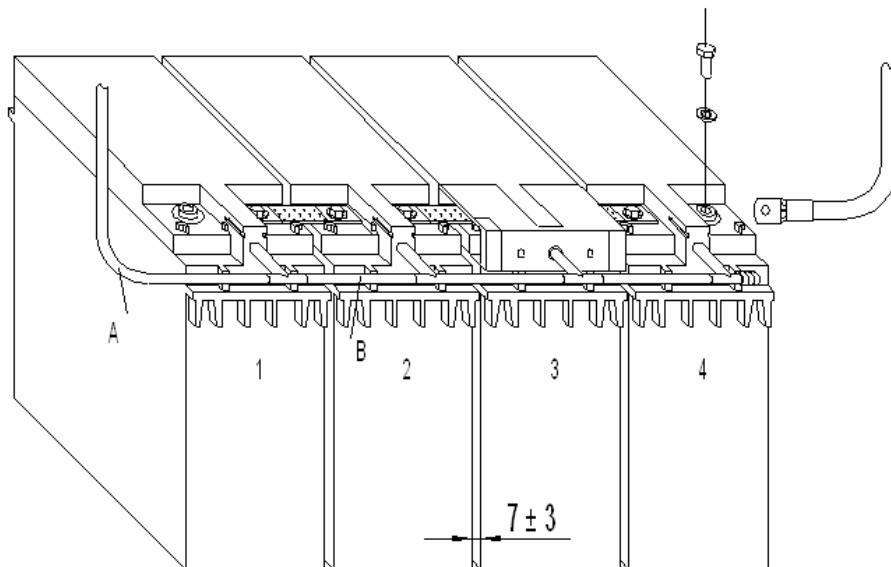

壳体技术特性

technical characteristics of container

长 L	宽 W	高 H	总高 max height	端子数 the number of pillars
395	105	270	270	2

EFTB12-80

EFTB12-85

连接配件

connecting accessories

照片 picture	名称 name	特性 characteristic	规格型号 reference	数量 QTY
	联接铜排 rigid connector between cells	90×20×3mm QDU.860(06).D06ZP(B)	FTP65/3	3
	接线端子 end lug	自制 QDU.890(02).D06DZ(B)	SC50-6A	3
	绝缘扳手 insulated spanner	QDU.950(05).D10WX	DB6	1
	数字序号 numbers	1 ~ 4		1
	排气管 Exhaust pipe	QDU.891.D01PG(A)		4
	导气管 air pipe	QDU.891.D00DG(A)	A: 5000mm	1
			B: 103mm	3
	排气管塞 air pipe closure	QDU.781.D01PS(A)		1
	电池护罩 battery shield	QDU.631.D06HZ(B)	出厂前 安装在 电池上	4
	接线组件 connection subassembly	QDU.516.D02JZ(B)(ABT)		8
	螺栓 screw	不锈钢 stainless steel		GB818-85-M8 × 16
	平垫 flat washer	QDU.931(01).D01DQ(A)		8

连线

drawing

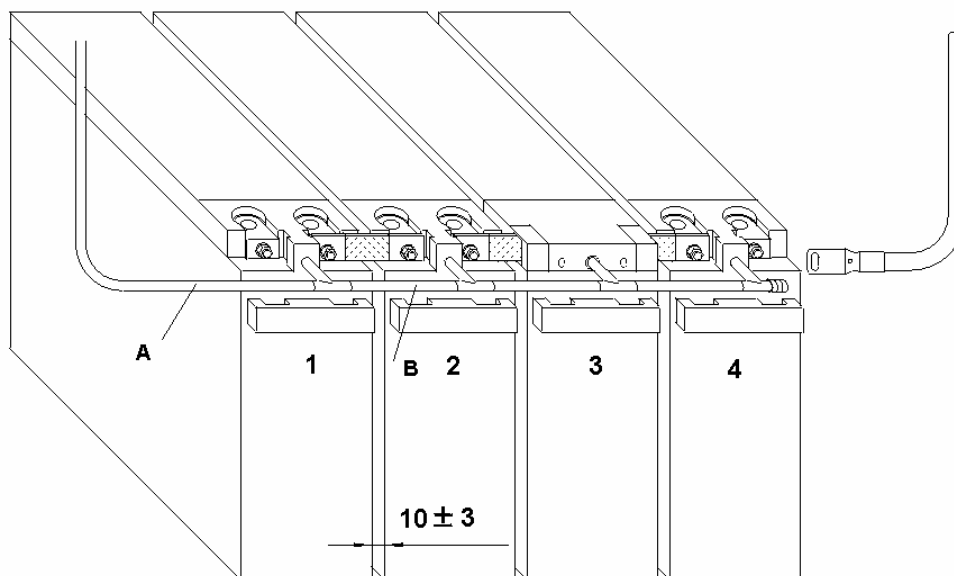

壳体技术特性

technical characteristics of container

长 L	宽 W	高 H	总高 max height	端子数 the number of pillars
508	110	238	238	2

EFTB12-100(前部连接 FC)

连接配件

connecting accessories

此连接方式适用于通信系统

This connection methods is suitable for Telecommunication system.

照片 picture	名称 name	特性 characteristic	规格型号 reference	数量 QTY
	联接铜排 rigid connector between cells	90×20×3mm QDU.860(06).D06ZP(B)	FTP65/3	3
	接线端子 end lug	自制 QDU.890(02).D06DZ(B)	SC50-6A	3
	绝缘扳手 insulated spanner	QDU.950(05).D10WX	DB6	1
	数字序号 numbers	1 ~ 4		1
	排气管 Exhaust pipe	QDU.891.D01PG(A)		4
	导气管 air pipe	QDU.891.D00DG(A)	A: 5000mm	1
			B: 108mm	3
	排气管塞 air pipe closure	QDU.781.D01PS(A)		1
	电池护罩 battery shield	QDU.631.D02HZ(B)(AB T)	出厂前 安装在 电池上	4
	接线组件 connection subassembly	QDU.516.D02JZ(B)(ABT)		8
	螺栓 screw	不锈钢 stainless steel		GB818-85-M8 × 16
	平垫 flat washer	QDU.931(01).D01DQ(A)		8

连线图

drawing

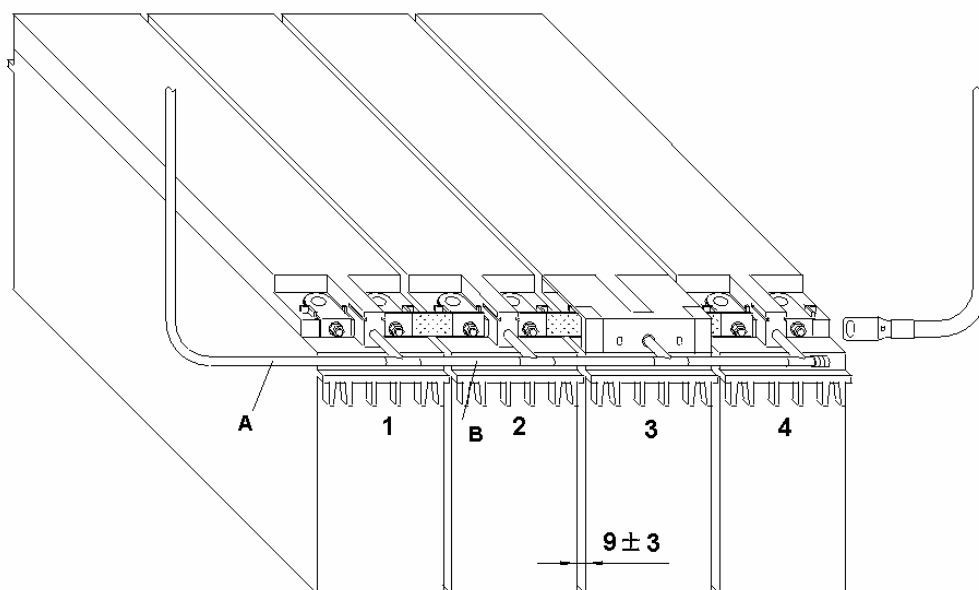

壳体技术特性

technical characteristics of container

长 L	宽 W	高 H	总高 max height	端子数 the number of pillars
508	110	238	238	2







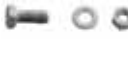

EFTB12-100 (顶部连接 TC)

连接配件

connecting accessories

此连接方式适用于 UPS 系统

This connection methods is suitable for UPS system

照片 picture	名称 name	特性 characteristic	规格型号 reference	数量 QTY
	联接铜排 rigid connector between cells	90x28x2mm QDU.860(18).D06ZP(T)	FTP65/2A	3
	螺栓 screw	不锈钢 stainless steel	GB/T5781-2000-C-M8x16	9
	平垫 flat Washer		QDU.931(01).D01DQ(A)	9
	螺母 nut		GB/T41-2000-C-M8	2
	接线端子 end lug	自制 QDU.890(01).D01DZ(A)	SC70-8A	3
	绝缘扳手 insulated spanner	QDU.950(02).A14WX	TB8	1
	数字序号 numbers	1 ~ 4		1
	排气管 Exhaust pipe	QDU.891.D01PG(A)		4
	导气管 air pipe	QDU.891.D00DG(A)	A: 5000mm	1
			B: 108mm	3
	排气管塞 air pipe closure	QDU.781.D01PS(A)		1
	电池护罩 battery shield	QDU.631.D02HZ(B)(ABT)	出厂前安装在电池上	4

连线图

drawing

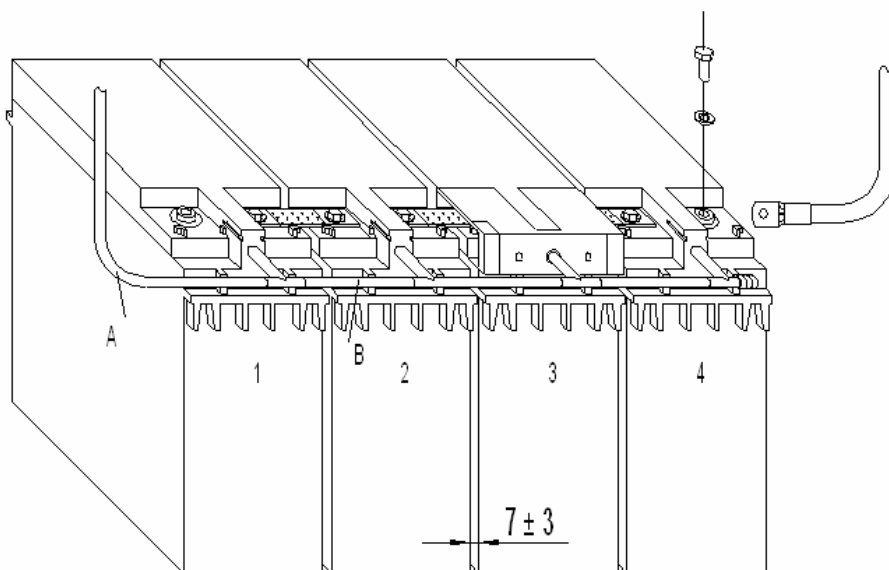

EFTB12-125 (前部连接 FC)
EFTB12-150 EFTB12-155 (前部连接 FC)

壳体技术特性

technical characteristics of container

连接配件

connecting accessories

此连接方式适用于通信系统

This connection methods is suitable for Telecommunication

长 L	宽 W	高 H	总高 max height	端子数 the number of pillars
551	110	320	320	2

照片 picture	名称 name	特性 characteristic	规格型号 reference	数量 QTY	
	联接铜排 rigid connector between cells	90x25x4mm QDU.860(13).D05ZP(E)	FTP65/4	3	
	接线端子 end lug	自制 QDU.890(01).D01DZ(A)	SC70-8A	3	
	绝缘扳手 insulated spanner	QDU.950(02).A14WX	TB8	1	
	数字序号 numbers	1 ~ 4		1	
	排气管 Exhaust pipe	QDU.891.D01PG(A)		4	
	排气管塞 air pipe closure	QDU.781.D01PS(A)		1	
	导气管 air pipe	QDU.891.D00DG(A)	A: 5000mm	1	
			B: 108mm	3	
	电池护罩 battery shield	QDU.631.D14HZ(B)(ABT)	出厂前 安装在 电池上	4	
	L型接线组件 L connection subassembly	QDU.516.D01JZ(A)		8	
	螺栓 screw	不锈钢 stainless steel		GB818-85-M8 x 16	8
	平垫 flat washer	QDU.931(01).D01DQ(A)			8

连线图
drawing

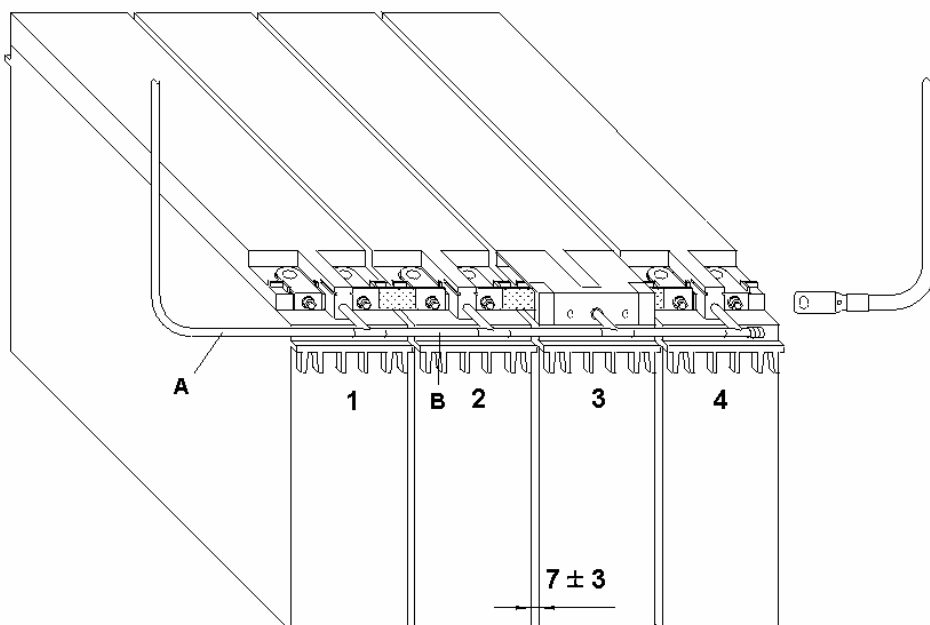

EFTB12-125 (顶部连接 TC)
EFTB12-150 EFTB12-155 (顶部连接 TC)

壳体技术特性

technical characteristics of container









连接配件

connecting accessories

此连接方式适用于 UPS 系统

This connection methods is suitable for UPS system

长 L	宽 W	高 H	总高 max height	端子数 the number of pillars
551	110	320	320	2

照片 picture	名称 name	特性 characteristic	规格型号 reference	数量 QTY
	联接铜排 rigid connector between cells	90x30x3.5mm QDU.860(19).D05ZP(T)	FTP65/3.5	3
	螺栓 screw	不锈钢 stainless steel	GB/T5781-2000-C-M8x16	9
	平垫 flat Washer		QDU.931(01).D01DQ(A)	9
	螺母 nut		GB/T41-2000-C-M8	2
	接线端子 end lug	自制 QDU.890(01).D01DZ(A)	SC70-8A	3
	绝缘扳手 insulated spanner	QDU.950(02).A14WX	TB8	1
	数字序号 numbers	1~4		1
	排气管 Exhaust pipe	QDU.891.D01PG(A)		4
	排气管塞 air pipe closure	QDU.781.D01PS(A)		1
	导气管 air pipe	QDU.891.D00DG(A)	A: 5000mm	1
			B: 108mm	3
	电池护罩 battery shield	QDU.631.D14HZ(B)(ABT)	出厂前安装在电池上	4

连线图

drawing

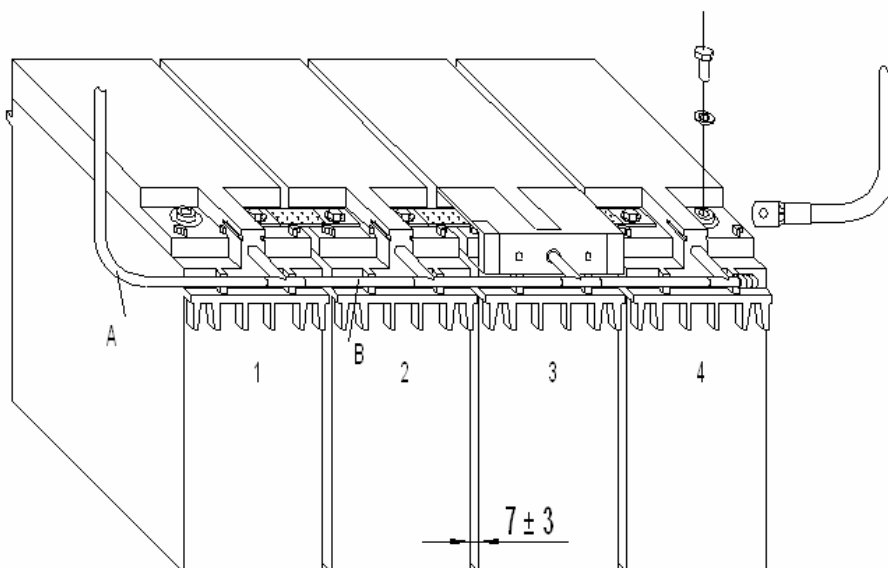

附页一：联接螺栓

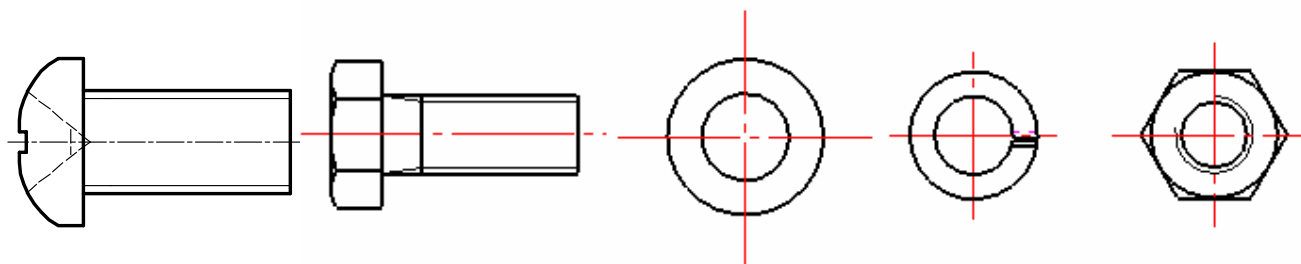

联接螺栓 GB818-85-M8 × 16 联接螺栓 GB/T5781-2000-C-M8 × 16 平垫圈 QDU.931(01).D01DQ(A) - 8 弹簧垫圈 GB859-1987 螺母 GB/T41-2000-C

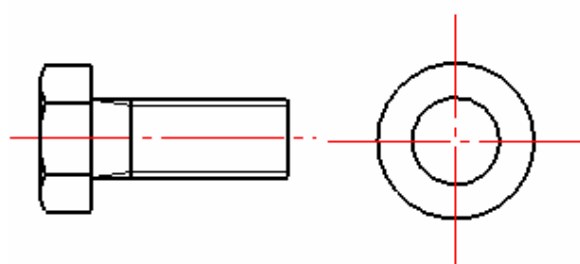

联接螺栓 GB/T5781-2000-C-M6 × 12 平垫圈 GB95-2002-C- 6

联接螺栓规格	平垫	弹簧垫	螺母	适用电池型号
GB/T5781-2000-C-M6 × 12	6		M6	EFTB12-50TC
GB/T5781-2000-C-M6 × 12	6			EFTB12-50FC
GB818-85-M8 × 16	8			EFTA12-100/125/150/160/175 EFTB12-80/85/100FC/125FC/150FC/155FC
GB/T5781-2000-C-M8 × 16	8		M8	EFTB12-100TC/125TC/150TC/155TC

注： 1、出口电池配件均为不锈钢材质；
2、如有特殊要求，需申购时标明；

附页二： 联接铜排

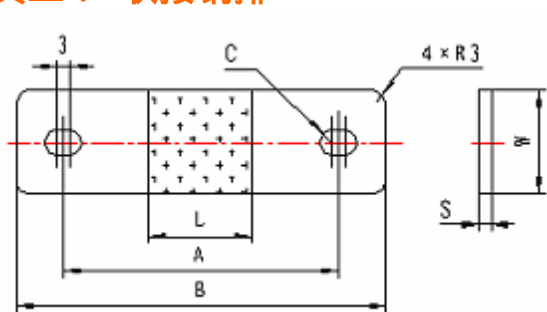

图示 1

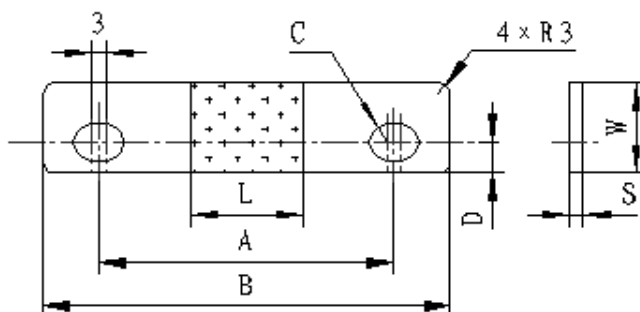

图示 2

代号	图示	热缩管长度 L(mm)	孔心距离 A(mm)	铜排长度 B(mm)	铜排宽度 W(mm)	厚度 S(mm)	半径 C(mm)	偏心距 D(mm)	适用电池型号
FTP60/2	2	30	60	85	20	2	R3	6	EFTB12-50FC
FTP60/2A	1	35	60	85	20	2	R3	/	EFTB12-50TC
FTP65/3	2	35	65	90	20	3	R3	6	EFTB12-80/85/100FC
FTP65/4	2	30	65	90	25	4	R4	8.5	EFTB12-125FC/150FC/155FC
FTP65/2A	1	35	65	90	28	2	R4	/	EFTB12-100TC
FTP65/3.5	1	35	65	90	30	3.5	R4	/	EFTB12-125TC/150TC/155TC
FTP75/3	2	35	75	100	25	3	R4	8.5	EFTA12-100
FTP75/4A	2	35	75	100	25	4	R4	8.5	EFTA12-125/150/160/175

- 注：1、联接铜排主要用于电池间的串联连接；
 2、上表中各图示的图纸编号参见前面配件清单；
 3、无特殊要求，铜排采取镀锡保护。

附页三：接线端子

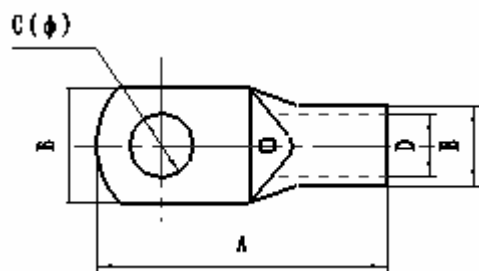

图示 1

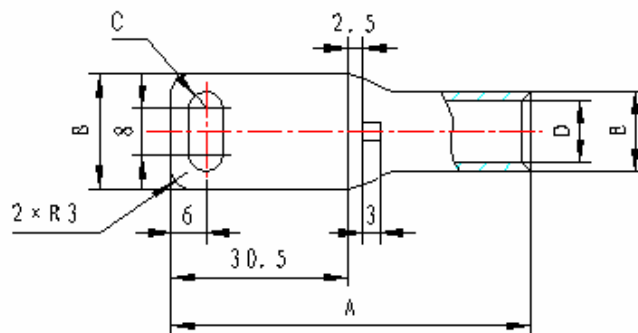

图示 2

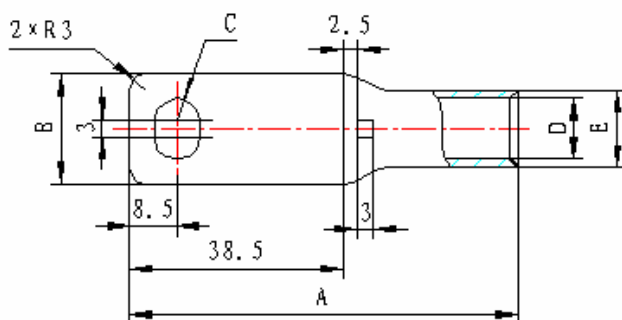

图示 3

代号	图示	插线片、铜鼻、接线端子外形尺寸 (mm)					适用电池型号
		A	B	C	D	E	
SC35-6	1	38	14	6.2	8.2	10.5	EFTB12-50TC
SC50-6A	2	62	20	R3	11	14	EFTB12-50FC/80/85/100FC
SC70-8A	3	70	20	R4	11	14	EFTA12-100/125/150/160/175 ; EFTB12-125FC/150FC/155FC EFTB12-100TC/125TC/150TC/155TC

注：1、无特殊要求，插线片、铜鼻、接线端子均镀锡；

2、图示 2 和图示 3 所示接线端子为自制，其图纸号为：

图示 2：QDU.890(02).D06DZ(B)；

图示 3：QDU.890(01).D01DZ(A)；

3、每种规格电池配置的 3 个接线端子仅用于制作电池组引出线连接电池一端，引出线另一端不予考虑。

附页四：绝缘扳手



图 示 1



图 示 2

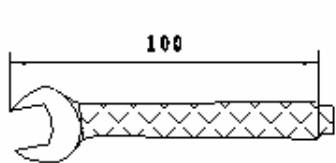

图 示 3

代号	图示	适用联接螺栓规格 GB/T5781-2000-C	适用螺母规格 GB/T41-2000-C	适用电池型号
DB6	1		M6	EFTB12-50FC/100FC EFTB12-80/85
TB6	2	M6 × 12		EFTB12-50TC
TB8	3		M8	EFTA12-100/125/150/160/175 ; EFTB12-125FC/150FC/155FC
		M8 × 16		EFTB12-100TC/125TC/150TC/155TC

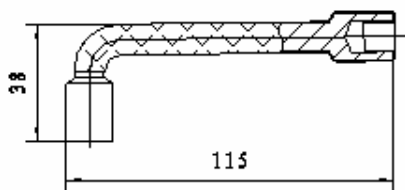
注： 1、绝缘扳手头部裸露，手柄及尾部用热缩管套封绝缘；

2、DB6 的图纸编号为 QDU.950(05). D10WX

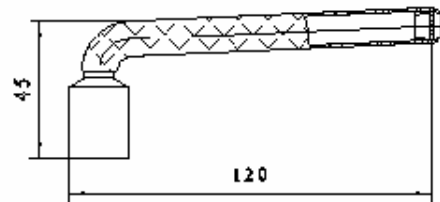
TB6 的图纸编号为 QDU.950(01). B00WX

TB8 的图纸编号为 QDU.950(02). A14WX